

Implementation of New Bridgeless Landsman Converter for EV Battery Charger

¹Shaista Parveen, ²Abdul Samad Ansari, ³Mohammad Shahid, ⁴Sundar Prakash Ranjan, ⁵Sanjay Kumar

^{1&2}Assistant Professor, Department of Electrical Engineering, Siwan Engineering & Technical Institute, Siwan, India

^{3&4&5}UG Scholar, Department of Electrical Engineering, Siwan Engineering & Technical Institute, Siwan, India

Abstract: An electric vehicle, also called an EV, uses one or more electric motors or traction motors for propulsion. Battery charger is an important part of EV because it works as a fuel for vehicles. This paper presents and implement of a new battery charger for electric vehicle with parameter improvement. In the present configuration, the conventional diode converter at the source end of existing electric vehicle (EV) battery charger is eliminated with modified Landsman power factor correction (PFC) converter. Power factor are essential concern of such type of system sothat it can become more robustness and useful.

Keywords: Electric vehicle (EV), Bridgeless, Battery charger, Power, Capacity, Landsman.

1. INTRODUCTION

In recent years the problems of "range anxiety" associated with electric vehicles (EVs) have been alleviated by the introduction hybrids (HEVs) and plug in hybrids (PHEVs) and the development of higher energy density batteries capable of storing more energy in the same space. With the increasing popularity of electric vehicles, "range anxiety" is now being replaced by "charging anxiety". This page addresses the issues associated with providing suitable chargers and the charging infrastructure necessary to support the growing population of EVs.

It takes about three minutes fill up a petrol or diesel engine car at a filling station with enough fuel to travel about 300 miles, costing about \$35 in th USA and about £52 (\$80) in the UK. To travel 300 miles in a small EV passenger car would need three full charges of a typical 25kWh battery used to power these vehicles costing about \$2.50 per charge in the USA with electricity priced at \$0.10 per unit (kWh) and £2.50 (\$3.90) in the UK with electricity priced at £0.10 per unit. The low energy cost is one of the attractions of owning an EV. Unfortunately to put the 25 kWh of energy needed to travel each 100 miles into the battery in the same time (1 minute) that the equivalent amount of diesel fuel is pumped into the tank would require a power supply capable of delivering a power of 1.5 MegaWatts. To put this into perspective, 25 kWh is the amount of energy an average household consumes in a whole day. Providing electrical distribution facilities to allow users to consume this amount of energy from the electricity grid in one minute is not practical and even if it was, no EV battery could accept energy at this rate. On the other hand neither is it practical to take 24 hours to charge the battery in a passenger electric vehicle.

The solutions don't just involve the development of chargers, they involve the design and roll out of a network of public and private charging stations with associated user authentication and billing systems, public safety and planning issues, the negotiation of international standards and beefing up the electricity grid to carry the increased load. There are no single answers to these issues. On the one hand, national and international standards organizations attempt to find definitive solutions to these issues, but there are so many competing national standards. On the other hand commercial enterprises attempt to leapfrog the competition by coming up

with new and unique innovative solutions to differentiate their offerings. Some of these issues are explored here.

A. Charger Requirements

First we need to scope out the requirements of the vehicles we are trying to accommodate and the batteries they use. The range is very wide with energy storage requirements ranging from 0.5 kWh to 50 kWh and current carrying capacity ranging from 20 Amps to 200 Amps requiring chargers purpose built to suit the applications.

Chargers provide a DC charging voltage from an AC source whether from a common socket outlet or more recently from a purpose built DC charging station. Most important are the methods of controlling the charge and protecting the battery from over-voltage, over-current and over-temperature. These charger functions are integrated with and unique to the battery.

Chargers for electric bikes are usually low cost, separate units. To save weight they are not usually mounted on the bike and charging takes place at home. Their power handling capacity is only sufficient for charging the relatively low power bike batteries and entirely unsuitable for passenger car applications.

Chargers for passenger cars are normally mounted inside the car. This is because the vehicle may be used a long way from home, further than the range possible from a single battery charge. For this reason they have to carry the charger with them on board the vehicle. Charging can be carried out at home from a standard domestic electricity socket outlet but the available power is very low and charging takes a long time, possibly ten hours or more depending on the size of the battery. Since charging is usually carried out overnight this is not necessarily a problem, but it could be if the car is away from its home base. Such low power charging is normally used in an emergency and most cars are fitted with a higher power charging option which can be used in commercial locations or with a higher power domestic installation. In many countries this higher power facility is implemented by means of a three phase electricity supply.

Commercial electric vehicles need bigger batteries which need higher power charging stations to achieve reasonable charging times but they also have extra options. Many of them follow prescribed delivery routes within a limited range from base and return to base in the evening. In these cases off board charging is possible saving weight and space on the vehicle. Such applications can also be adapted to battery swap options. Each vehicle may have two batteries with one being charged while the other is in use. When used in long distance shuttle applications this can double the effective range of the vehicle. The vehicle depletes the battery during each journey and picks up a fully charged battery at the terminus leaving the discharged battery to be recharged ready for the next trip. This shuttle option however needs three batteries per vehicle.

There are three fundamental kinds of electric vehicles (EVs), classed by the degree that electricity is utilized as their vitality source. BEVs, or battery electric vehicles, PHEVs of plug-in hybrid electric vehicles, and HEVs, or hybrid electric vehicles. Just BEVs are fit for charging on a level 3, DC fast charge.

2. BACKGROUND

R. Kushwaha et al., [1] This work deals with the design and implementation of a new charger for a battery-operated electric vehicle (EV) with power factor improvement at the front end. In the present configuration, the conventional diode converter at the source end of existing EV battery charger is eliminated with the

modified Landsman power factor correction (PFC) converter. The PFC converter is cascaded to a flyback isolated converter, which yields the EV battery control to charge it, first in constant current mode then switching to constant voltage mode. The present PFC converter is controlled using single sensed entity to achieve the robust regulation of dc-link voltage as well as to ensure the unity power factor operation.

G. Hilton et al., [2] High rate (<100 kW) electric vehicle chargers (HREVCs) are crucial for achieving the benefits of reduced CO₂ and particulate emissions promised by EVs by enabling journey distances greater than the range of the vehicle. A method for predicting the expected demand pattern at these HREVCs is presented in this work.

J. Lu et al., [3] This work presents a method for efficiency estimation of boost-derived continuous conduction mode power factor correction (CCM-PFC) converters for electric vehicle (EV) onboard chargers. The present methodology incorporates converter nonidealities, especially caused by magnetic components. The value of magnetizing inductance in an inductor or transformer core does not remain constant over variable current levels, which causes non uniform power losses at different current levels.

J. Lu et al., [4] The goal is to secure zero-voltage-switching for all switches at all voltage range. Such control strategy is further optimized incorporating with the switch parasitic capacitance and dead band settings. To further enhance the charger performance, GaN HEMTs are equipped to the on-board charger aiming at higher efficiency and higher power density than Si devices. Experimental results indicated that such charger with present control strategy embraces the peak efficiency of >97% at 7.2 kW and a power density of ~4 kW/L.

B. Lee et al., [5] This work suggests another candidate for isolated/bidirectional dc/dc converter in electric vehicle on-board charger based on PWM resonant converter (RC). The PWM-RC has good switching characteristics but it is not adequate for bidirectional applications because it is always operated under “buck type” operation regardless of power flow directions. This problem can be solved by structure change method, which increases the converter gain into double. Also, additional technique to increase the converter gain during discharging operation is suggested by analysis of the gain characteristics. The feasibility of bidirectional PWM-RC is verified with a 6.6-kW prototype charger.

3. SIMULINK MODEL AND SIMULATION RESULTS

The modified Landsman converter fed battery charger consists of two stages, a modified BL converter for improved input wave-shaping and an isolated converter for the charging of EV battery during constant current (CC) constant voltage (CV) conditions.

The operation of the modified converter is selected in DCM or CCM mode based on the application requirement of low cost or low device stress, respectively.

BL converter fed EV battery charger with regulated DC link voltage at an intermediate stage. The input side of the present charger is fed by a single phase AC source.

The input DBR is eliminated by two Landsman converters, which operates in parallel during the positive half line and negative half line, separately. Therefore, the conduction losses are reduced to half due to reduced number of components conducting in one switching cycle.

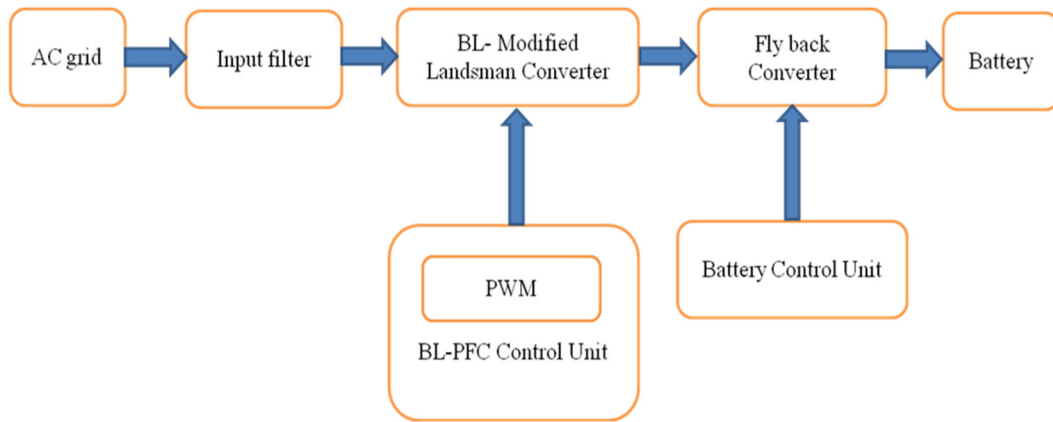

Figure 1: Flow Chart

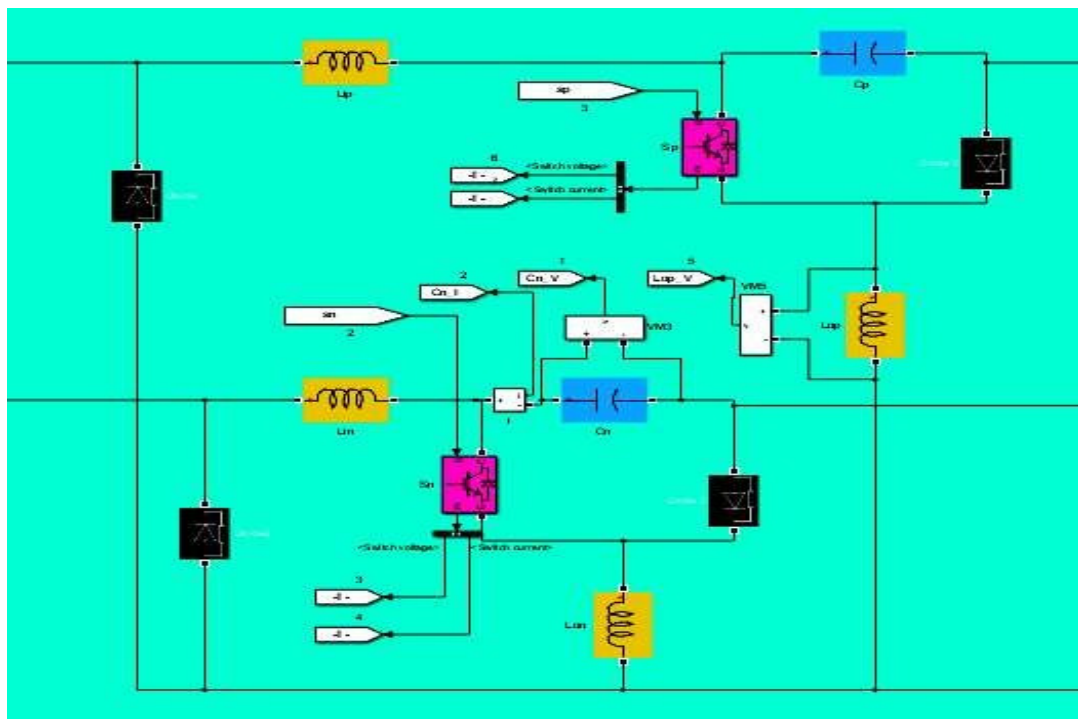

Figure 2: New Landsman Converter

Figure 2 is showing landsman converter circuit. Where Implements a diode in parallel with a series RC snubber circuit. In on-state the Diode model has an internal resistance (R_{on}) and inductance (L_{on}).

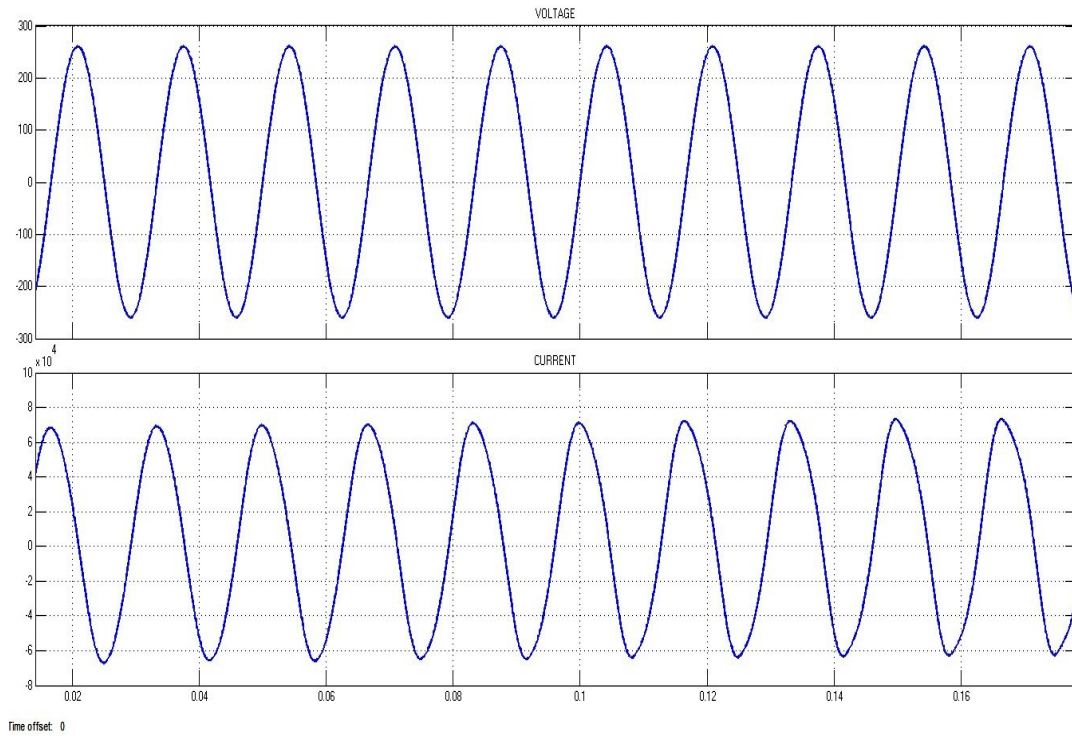

Figure 3: Output of Ac source voltage and current

Figure 3 presents output of source voltage is 260V and 7A current.

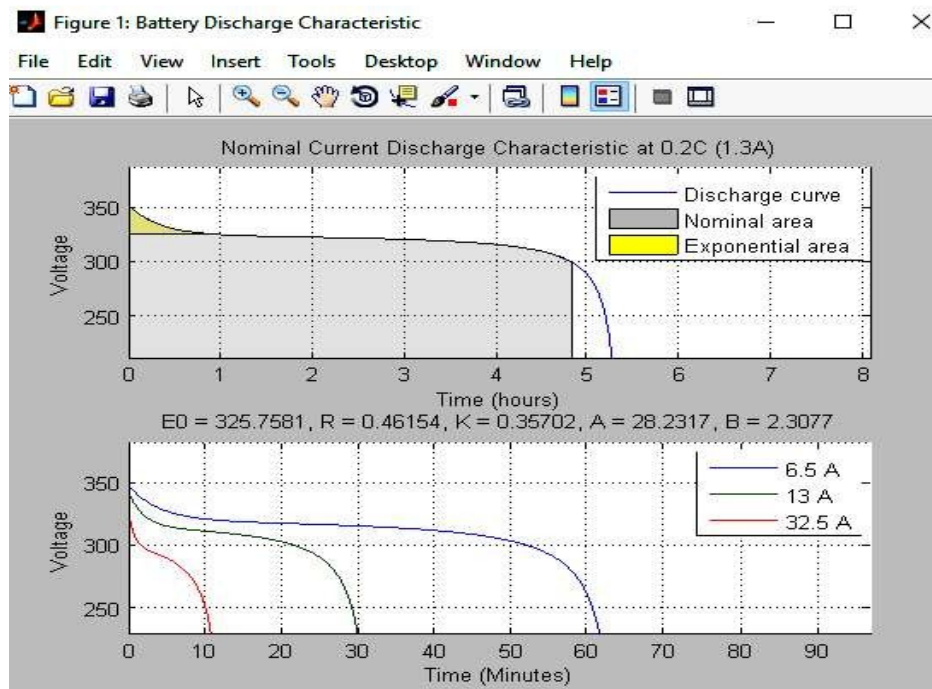

Figure 4: Battery discharge characteristic

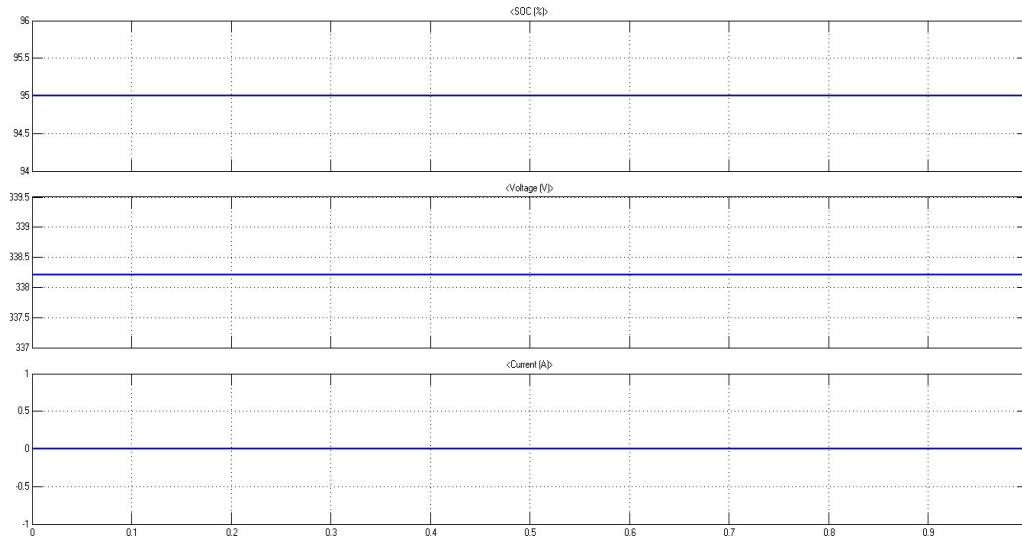

Figure 5: Performance of Battery

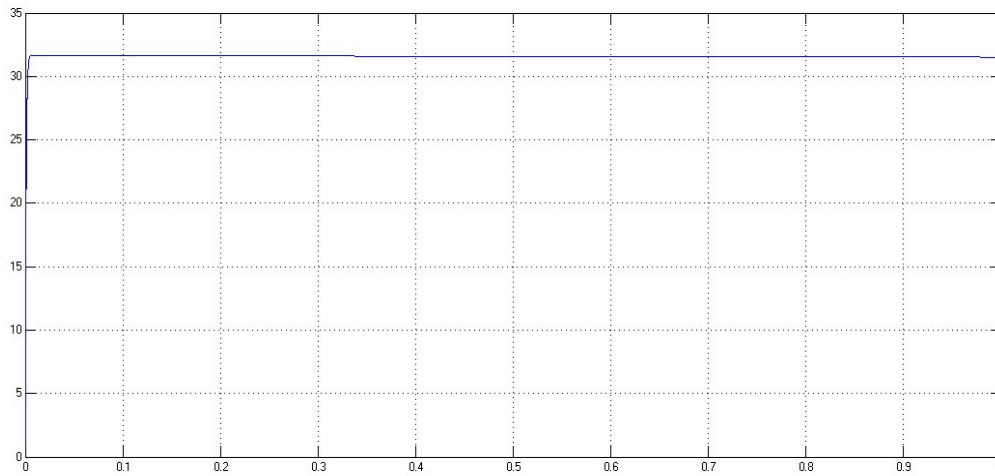

Figure 6: Battery output current

Figure 5 and 6 is showing output performance of battery. Here it can be seen that state of charge of battery is 95% and voltage is 338.25V and current is 33A.

Table 1: Comparison of present design result with previous design result

Sr No.	Parameter	Previous Model	Present Model
1	Number of components	Increased	Constant
2	Control (with PFC)	Voltage Follower	Voltage Follower
3	Power density	0.369kW/kg	0.32W/kg
4	Power factor	0.88	0.90
5	Efficiency	91%	95%

Table 1 showing comparison of present model results with previous design model results in terms of output voltage, rated power, efficiency, power factor etc. Therefore above result shows, present model give significant improved result rather than then the existing model.

4. CONCLUSION

A new EV charger with Bridgeless Landsman converter followed by a flyback converter has been present, analyzed, and validated in this work to charge an EV battery with inherent PF Correction. The design and control of the present EV charger in DCM mode have offered the advantage of reduced number of sensors at the output. Moreover, the present BL converter has reduced the input and output current ripples due to inductors both in input and output of the converter.

REFERENCES

- [1] R. Kushwaha and B. Singh, "Power Factor Improvement in Modified Bridgeless Landsman Converter Fed EV Battery Charger," in *IEEE Transactions on Vehicular Technology*, vol. 68, no. 4, pp. 3325-3336, April 2019.
- [2] G. Hilton, M. Kiaee, T. Bryden, B. Dimitrov, A. Cruden and A. Mortimer, "A Stochastic Method for Prediction of the Power Demand at High Rate EV Chargers," in *IEEE Transactions on Transportation Electrification*, vol. 4, no. 3, pp. 744-756, Sept. 2018.
- [3] J. Lu, A. Mallik and A. Khaligh, "Dynamic Strategy for Efficiency Estimation in a CCM-Operated Front-End PFC Converter for Electric Vehicle Onboard Charger," in *IEEE Transactions on Transportation Electrification*, vol. 3, no. 3, pp. 545-553, Sept. 2017
- [4] J. Lu *et al.*, "Applying Variable-Switching-Frequency Variable-Phase-Shift Control and E-Mode GaN HEMTs to an Indirect Matrix Converter-Based EV Battery Charger," in *IEEE Transactions on Transportation Electrification*, vol. 3, no. 3, pp. 554-564, Sept. 2017.
- [5] B. Lee, J. Kim, S. Kim and J. Lee, "An Isolated/Bidirectional PWM Resonant Converter for V2G(H) EV On-Board Charger," in *IEEE Transactions on Vehicular Technology*, vol. 66, no. 9, pp. 7741-7750, Sept. 2017
- [6] N. Bodo, E. Levi, I. Subotic, J. Espina, L. Empringham and C. M. Johnson, "Efficiency Evaluation of Fully Integrated On-Board EV Battery Chargers With Nine-Phase Machines," in *IEEE Transactions on Energy Conversion*, vol. 32, no. 1, pp. 257-266, March 2017.
- [7] M. A. Awadallah, B. N. Singh and B. Venkatesh, "Impact of EV Charger Load on Distribution Network Capacity: A Case Study in Toronto," in *Canadian Journal of Electrical and Computer Engineering*, vol. 39, no. 4, pp. 268-273, Fall 2016
- [8] X. Wang, C. Jiang, B. Lei, H. Teng, H. K. Bai and J. L. Kirtley, "Power-Loss Analysis and Efficiency Maximization of a Silicon-Carbide MOSFET-Based Three-Phase 10-kW Bidirectional EV Charger Using Variable-DC-Bus Control," in *IEEE Journal of Emerging and Selected Topics in Power Electronics*, vol. 4, no. 3, pp. 880-892, Sept. 2016.
- [9] M. S. Diab, A. A. Elserougi, A. S. Abdel-Khalik, A. M. Massoud and S. Ahmed, "A Nine-Switch-Converter-Based Integrated Motor Drive and Battery Charger System for EVs Using Symmetrical Six-Phase Machines," in *IEEE Transactions on Industrial Electronics*, vol. 63, no. 9, pp. 5326-5335, Sept. 2016.
- [10] S. Moon and G. Moon, "Wireless Power Transfer System With an Asymmetric Four-Coil Resonator for Electric Vehicle Battery Chargers," in *IEEE Transactions on Power Electronics*, vol. 31, no. 10, pp. 6844-6854, Oct. 2016.
- [11] I. Subotic, N. Bodo and E. Levi, "Single-Phase On-Board Integrated Battery Chargers for EVs Based on Multiphase Machines," in *IEEE Transactions on Power Electronics*, vol. 31, no. 9, pp. 6511-6523, Sept. 2016.
- [12] G. Buja, R. K. Jha, M. Bertoluzzo and M. K. Naik, "Analysis and comparison of two wireless battery charger arrangements for electric vehicles," in *Chinese Journal of Electrical Engineering*, vol. 1, no. 1, pp. 50-57, Dec. 2015.